



*Agricultural Research Council*

*Animal Production Institute*

*Old Olifantsfontein Road*

*Irene*

## **Tender ADDENDUM Notice**

### **THE APPOINTMENT OF A SERVICE PROVIDER /S FOR PROPOSALS OF NEW FACILITIES AND RENOVATIONS / ENHANCEMENT OF EXISTING FACILITIES FOR ARC IRENE ANIMAL PRODUCTION AND KGORA TRAINING CENTER**

Notice is hereby given of the following changes/additions/exclusions to the tender technical enquiries:

- Additions to Annexure A and Annexure B Irene and Kgora respectively after site meetings held 11 March and 13 March 2025
- Closing date and time: 31 March 2025 @ 11H00 AM

#### **Technical Enquiries:**

Technical Enquiries:

Name: Dr. Tinette Van Wyk

Contact number: 012 672-9035

Email: [VanWykT@arc.agric.za](mailto:VanWykT@arc.agric.za)

Contact: SCM Enquiries

Supply Chain Management – Animal Production Institute

Mr SNgomane

Email: [ngomanesi@arc.agric.co.za](mailto:ngomanesi@arc.agric.co.za)

Telephone: 012 672 9120



**AGRICULTURAL RESEARCH COUNCIL**

**INVITATION TO BID:**

**ADDENDUM RFP NO: ARC/60/02/2025**

**THE APPOINTMENT OF A SERVICE PROVIDER /S FOR PROPOSALS OF NEW FACILITIES AND RENOVATIONS / ENHANCEMENT OF EXISTING FACILITIES FOR ARC IRENE ANIMAL PRODUCTION AND KGORA TRAINING CENTER**

**Technical Enquiries:**

**Name: Dr. Tinette Van Wyk**

**Contact number: 012 672-9035**

**Email: [VanWykT@arc.agric.za](mailto:VanWykT@arc.agric.za)**

COMPANY NAME	SUPPLIER REGISTRATION NUMBER	UNIQUE REGISTRATION NUMBER	
			<b>Main Contractor</b>
			<b>sub- contracted / joint venture 1</b>
			<b>sub-contractor / joint venture</b>

**COMPULSORY BRIEFING SESSIONS**

**Venue:** ARC Irene campus, Old, Olifantsfontein Rd, Irene, 0062 (Main Building)

**Date:** 11 March 2025

**Time:** 10H00 AM

**Venue:** KGORA training centre North West Mafikeng

**Date:** 13 March 2025

**Time:** 10H00 AM

**CLOSING DATE: 31 MARCH 2025 TIME: 11:00 AM**

**THE DETAILS AND CONTENTS OF THIS DOCUMENT ARE CONFIDENTIAL AND FOR CONSIDERATION AND RESPONSE BY THE RECORDED RECIPIENTS ONLY**



## PART A INVITATION TO BID

<b>YOU ARE HEREBY INVITED TO BID FOR REQUIREMENTS OF THE (NAME OF DEPARTMENT/ PUBLIC ENTITY)</b>					
RF#: ARC/60/02/2025	CLOSING DATE:	31 MARCH 2025	CLOSING TIME:	11:00	
DESCRIPTION	THE APPOINTMENT OF A SERVICE PROVIDER /S FOR PROPOSALS OF NEW FACILITIES AND RENOVATIONS / ENHANCEMENT OF EXISTING FACILITIES FOR ARC IRENE ANIMAL PRODUCTION AND KGORA TRAINING CENTER				
<b>BID RESPONSE DOCUMENTS MAY BE DEPOSITED IN THE BID BOX SITUATED AT (STREET ADDRESS)</b>					
<b>ARC MAIN BUILDING (ANIMAL PRODUCTION )</b>					
<b>OLD OLIFANSFONTEIN ROAD , IRENE, PRETORIA, 0062</b>					
<b>BIDDING PROCEDURE ENQUIRIES MAY BE DIRECTED TO</b>			<b>TECHNICAL ENQUIRIES MAY BE DIRECTED TO:</b>		
CONTACT PERSON	Joshua Ngomane		CONTACT PERSON	Dr. Tinette Van Wyk	
TELEPHONE NUMBER	012-672-9120		TELEPHONE NUMBER	012 672-9035	
FACSIMILE NUMBER			FACSIMILE NUMBER		
E-MAIL ADDRESS	ngomanesj@arc.agric.za		E-MAIL ADDRESS	VanWykT@arc.agric.za	
<b>SUPPLIER INFORMATION</b>					
NAME OF BIDDER					
POSTAL ADDRESS					
STREET ADDRESS					
TELEPHONE NUMBER	CODE		NUMBER		
CELLPHONE NUMBER					
FACSIMILE NUMBER	CODE		NUMBER		
E-MAIL ADDRESS					
VAT REGISTRATION NUMBER					
SUPPLIER COMPLIANCE STATUS	TAX COMPLIANCE SYSTEM PIN:		OR	CENTRAL SUPPLIER DATABASE No:	MAAA
B-BBEE STATUS LEVEL VERIFICATION CERTIFICATE	TICK APPLICABLE BOX] <input type="checkbox"/> Yes <input type="checkbox"/> No		B-BBEE STATUS LEVEL SWORN AFFIDAVIT	[TICK APPLICABLE BOX] <input type="checkbox"/> Yes <input type="checkbox"/> No	
<b>[A B-BBEE STATUS LEVEL VERIFICATION CERTIFICATE/ SWORN AFFIDAVIT (FOR EMES &amp; QSEs) MUST BE SUBMITTED IN ORDER TO QUALIFY FOR PREFERENCE POINTS FOR B-BBEE]</b>					
ARE YOU THE ACCREDITED REPRESENTATIVE IN SOUTH AFRICA FOR THE GOODS /SERVICES /WORKS OFFERED?	<input type="checkbox"/> Yes <input type="checkbox"/> No [[IF YES ENCLOSE PROOF]		ARE YOU A FOREIGN BASED SUPPLIER FOR THE GOODS /SERVICES /WORKS OFFERED?	<input type="checkbox"/> Yes <input type="checkbox"/> No [[IF YES, ANSWER THE QUESTIONNAIRE BELOW ]	
<b>QUESTIONNAIRE TO BIDDING FOREIGN SUPPLIERS</b>					
IS THE ENTITY A RESIDENT OF THE REPUBLIC OF SOUTH AFRICA (RSA)?				<input type="checkbox"/> YES <input type="checkbox"/> NO	
DOES THE ENTITY HAVE A BRANCH IN THE RSA?				<input type="checkbox"/> YES <input type="checkbox"/> NO	
DOES THE ENTITY HAVE A PERMANENT ESTABLISHMENT IN THE RSA?				<input type="checkbox"/> YES <input type="checkbox"/> NO	
DOES THE ENTITY HAVE ANY SOURCE OF INCOME IN THE RSA?				<input type="checkbox"/> YES <input type="checkbox"/> NO	
IS THE ENTITY LIABLE IN THE RSA FOR ANY FORM OF TAXATION?				<input type="checkbox"/> YES <input type="checkbox"/> NO	
<b>IF THE ANSWER IS "NO" TO ALL OF THE ABOVE, THEN IT IS NOT A REQUIREMENT TO REGISTER FOR A TAX COMPLIANCE STATUS SYSTEM PIN CODE FROM THE SOUTH AFRICAN REVENUE SERVICE (SARS) AND IF NOT REGISTER AS PER 2.3 BELOW.</b>					

**PART B  
TERMS AND CONDITIONS FOR BIDDING**

<b>1. BID SUBMISSION:</b>
<p>1.1. BIDS MUST BE DELIVERED BY THE STIPULATED TIME TO THE CORRECT ADDRESS. LATE BIDS WILL NOT BE ACCEPTED FOR CONSIDERATION.</p> <p>1.2. <b>ALL BIDS MUST BE SUBMITTED ON THE OFFICIAL FORMS PROVIDED–(NOT TO BE RE-TYPED) OR IN THE MANNER PRESCRIBED IN THE BID DOCUMENT.</b></p> <p>1.3. THIS BID IS SUBJECT TO THE PREFERENTIAL PROCUREMENT POLICY FRAMEWORK ACT, 2000 AND THE PREFERENTIAL PROCUREMENT REGULATIONS, 2022, THE GENERAL CONDITIONS OF CONTRACT (GCC) AND, IF APPLICABLE, ANY OTHER SPECIAL CONDITIONS OF CONTRACT.</p> <p>1.4. <b>THE SUCCESSFUL BIDDER WILL BE REQUIRED TO FILL IN AND SIGN A WRITTEN CONTRACT FORM (SBD7).</b></p>
<b>2. TAX COMPLIANCE REQUIREMENTS</b>
<p>2.1 BIDDERS MUST ENSURE COMPLIANCE WITH THEIR TAX OBLIGATIONS.</p> <p>2.2 BIDDERS ARE REQUIRED TO SUBMIT THEIR UNIQUE PERSONAL IDENTIFICATION NUMBER (PIN) ISSUED BY SARS TO ENABLE THE ORGAN OF STATE TO VERIFY THE TAXPAYER'S PROFILE AND TAX STATUS.</p> <p>2.3 APPLICATION FOR TAX COMPLIANCE STATUS (TCS) PIN MAY BE MADE VIA E-FILING THROUGH THE SARS WEBSITE WWW.SARS.GOV.ZA.</p> <p>2.4 BIDDERS MAY ALSO SUBMIT A PRINTED TCS CERTIFICATE TOGETHER WITH THE BID.</p> <p>2.5 IN BIDS WHERE CONSORTIA / JOINT VENTURES / SUB-CONTRACTORS ARE INVOLVED, EACH PARTY MUST SUBMIT A SEPARATE TCS CERTIFICATE / PIN / CSD NUMBER.</p> <p>2.6 WHERE NO TCS PIN IS AVAILABLE BUT THE BIDDER IS REGISTERED ON THE CENTRAL SUPPLIER DATABASE (CSD), A CSD NUMBER MUST BE PROVIDED.</p> <p>2.7 NO BIDS WILL BE CONSIDERED FROM PERSONS IN THE SERVICE OF THE STATE, COMPANIES WITH DIRECTORS WHO ARE PERSONS IN THE SERVICE OF THE STATE, OR CLOSE CORPORATIONS WITH MEMBERS PERSONS IN THE SERVICE OF THE STATE.”</p>

**NB: FAILURE TO PROVIDE / OR COMPLY WITH ANY OF THE ABOVE PARTICULARS MAY RENDER THE BID INVALID.**

SIGNATURE OF BIDDER: .....

CAPACITY UNDER WHICH THIS BID IS SIGNED: .....  
(Proof of authority must be submitted e.g. company resolution)

DATE: .....

**PRICING SCHEDULE**  
**(Professional Services)**

NAME OF BIDDER: .....	RFP NO.: ARC/60/02/2025.....
CLOSING TIME 11:00	CLOSING DATE 31 March 2025...

OFFER TO BE VALID FOR ...120.....DAYS FROM THE CLOSING DATE OF BID.

ITEM NO	DESCRIPTION	BID PRICE IN RSA CURRENCY **(ALL APPLICABLE TAXES INCLUDED)
---------	-------------	--

1. The accompanying information must be used for the formulation of proposals.
2. Bidders are required to indicate a ceiling price based on the total estimated time for completion of all phases and including all expenses inclusive of all applicable taxes for the project. R.....

3. PERSONS WHO WILL BE INVOLVED IN THE PROJECT AND RATES APPLICABLE (CERTIFIED INVOICES MUST BE RENDERED IN TERMS HEREOF)

4. PERSON AND POSITION	HOURLY RATE	DAILY RATE
.....	R.....	.....
.....	R.....	.....
.....	R.....	.....
.....	R.....	.....
.....	R.....	.....

5. PHASES ACCORDING TO WHICH THE PROJECT WILL BE COMPLETED, COST PER PHASE AND MAN-DAYS TO BE SPENT

.....	R.....	..... days
.....	R.....	..... days
.....	R.....	..... days
.....	R.....	..... days

5.1 Travel expenses (specify, for example rate/km and total km, class of airtravel, etc). Only actual costs are recoverable. Proof of the expenses incurred must accompany certified invoices.

DESCRIPTION OF EXPENSE TO BE INCURRED	RATE	QUANTITY	AMOUNT
.....	.....	.....	R.....
.....	.....	.....	R.....
.....	.....	.....	R.....
.....	.....	.....	R.....

TOTAL: R.....

\*\* "all applicable taxes" includes value-added tax, pay as you earn, income tax, unemployment insurance contributions and skills development levies.

Name of Bidder: .....

5.2 Other expenses, for example accommodation (specify, eg. Three star hotel, bed and breakfast, telephone cost, reproduction cost, etc.). On basis of these particulars, certified invoices will be checked for correctness. Proof of the expenses must accompany invoices.

DESCRIPTION OF EXPENSE TO BE INCURRED	RATE	QUANTITY	AMOUNT
.....	.....	.....	R.....
.....	.....	.....	R.....
.....	.....	.....	R.....
.....	.....	.....	R.....
TOTAL: R.....			

- 6. Period required for commencement with project after acceptance of bid .....  
.....
- 7. Estimated man-days for completion of project .....  
.....
- 8. Are the rates quoted firm for the full period of contract? ..... \*YES/NO
- 9. If not firm for the full period, provide details of the basis on which adjustments will be applied for, for example consumer price index. ....  
.....  
.....  
.....

**\*[DELETE IF NOT APPLICABLE]**

Any enquiries regarding bidding procedures may be directed to the –

AGRICULTURAL REASERACH COUNCIL  
OLD OLIFANSFONTEIN ROAD, IRENE, PRETORIA, 0062

Technical information

Name: Dr. Tinette Van Wyk  
Contact number: 012 672-9035  
Email: [VanWykT@arc.agric.za](mailto:VanWykT@arc.agric.za)  
SCM contact person

Name: Joshua Ngomane  
Tel: 012-672-9120  
Email: [ngomanesj@arc.agric.za](mailto:ngomanesj@arc.agric.za)

## BIDDER'S DISCLOSURE

### 1. PURPOSE OF THE FORM

Any person (natural or juristic) may make an offer or offers in terms of this invitation to bid. In line with the principles of transparency, accountability, impartiality, and ethics as enshrined in the Constitution of the Republic of South Africa and further expressed in various pieces of legislation, it is required for the bidder to make this declaration in respect of the details required hereunder.

Where a person/s are listed in the Register for Tender Defaulters and / or the List of Restricted Suppliers, that person will automatically be disqualified from the bid process.

### 2. Bidder's declaration

2.1 Is the bidder, or any of its directors / trustees / shareholders / members / partners or any person having a controlling interest<sup>1</sup> in the enterprise, employed by the state? **YES/NO**

2.1.1 If so, furnish particulars of the names, individual identity numbers, and, if applicable, state employee numbers of sole proprietor/ directors / trustees / shareholders / members/ partners or any person having a controlling interest in the enterprise, in table below.

Full Name	Identity Number	Name of State institution

2.2 Do you, or any person connected with the bidder, have a relationship

---

<sup>1</sup> the power, by one person or a group of persons holding the majority of the equity of an enterprise, alternatively, the person/s having the deciding vote or power to influence or to direct the course and decisions of the enterprise.

with any person who is employed by the procuring institution? **YES/NO**

2.2.1 If so, furnish particulars:

.....  
.....

2.3 Does the bidder or any of its directors / trustees / shareholders / members / partners or any person having a controlling interest in the enterprise have any interest in any other related enterprise whether or not they are bidding for this contract? **YES/NO**

2.3.1 If so, furnish particulars:

.....  
.....

**3 DECLARATION**

I, \_\_\_\_\_ the \_\_\_\_\_ undersigned, (name)..... in submitting the accompanying bid, do hereby make the following statements that I certify to be true and complete in every respect:

- 3.1 I have read and I understand the contents of this disclosure;
- 3.2 I understand that the accompanying bid will be disqualified if this disclosure is found not to be true and complete in every respect;
- 3.3 The bidder has arrived at the accompanying bid independently from, and without consultation, communication, agreement or arrangement with any competitor. However, communication between partners in a joint venture or consortium<sup>2</sup> will not be construed as collusive bidding.
- 3.4 In addition, there have been no consultations, communications, agreements or arrangements with any competitor regarding the quality, quantity, specifications, prices, including methods, factors or formulas used to calculate prices, market allocation, the intention or decision to submit or not to submit the bid, bidding with the intention not to win the bid and conditions or delivery particulars of the products or services to which this bid invitation relates.
- 3.4 The terms of the accompanying bid have not been, and will not be, disclosed by the bidder, directly or indirectly, to any competitor, prior to the date and time of the official bid opening or of the awarding of the contract.
- 3.5 There have been no consultations, communications, agreements or arrangements made by the bidder with any official of the procuring

---

<sup>2</sup> Joint venture or Consortium means an association of persons for the purpose of combining their expertise, property, capital, efforts, skill and knowledge in an activity for the execution of a contract.



**SBD4**

institution in relation to this procurement process prior to and during the bidding process except to provide clarification on the bid submitted where so required by the institution; and the bidder was not involved in the drafting of the specifications or terms of reference for this bid.

- 3.6 I am aware that, in addition and without prejudice to any other remedy provided to combat any restrictive practices related to bids and contracts, bids that are suspicious will be reported to the Competition Commission for investigation and possible imposition of administrative penalties in terms of section 59 of the Competition Act No 89 of 1998 and or may be reported to the National Prosecuting Authority (NPA) for criminal investigation and or may be restricted from conducting business with the public sector for a period not exceeding ten (10) years in terms of the Prevention and Combating of Corrupt Activities Act No 12 of 2004 or any other applicable legislation.

I CERTIFY THAT THE INFORMATION FURNISHED IN PARAGRAPHS 1, 2 and 3 ABOVE IS CORRECT.

I ACCEPT THAT THE STATE MAY REJECT THE BID OR ACT AGAINST ME IN TERMS OF PARAGRAPH 6 OF PFMA SCM INSTRUCTION 03 OF 2021/22 ON PREVENTING AND COMBATING ABUSE IN THE SUPPLY CHAIN MANAGEMENT SYSTEM SHOULD THIS DECLARATION PROVE TO BE FALSE.

.....	.....
Signature	Date
.....	.....
Position	Name of bidder

## PREFERENCE POINTS CLAIM FORM IN TERMS OF THE PREFERENTIAL PROCUREMENT REGULATIONS 2022

This preference form must form part of all tenders invited. It contains general information and serves as a claim form for preference points for specific goals.

**NB: BEFORE COMPLETING THIS FORM, TENDERERS MUST STUDY THE GENERAL CONDITIONS, DEFINITIONS AND DIRECTIVES APPLICABLE IN RESPECT OF THE TENDER AND PREFERENTIAL PROCUREMENT REGULATIONS, 2022**

### 1. GENERAL CONDITIONS

1.1 The following preference point systems are applicable to invitations to tender:

- the 80/20 system for requirements with a Rand value of up to R50 000 000 (all applicable taxes included); and

1.2 **To be completed by the organ of state**

*(delete whichever is not applicable for this tender).*

- a) The applicable preference point system for this tender is the 80/20 preference point system.
- b) The 80/20 preference point system will be applicable in this tender. The lowest/highest acceptable tender will be used to determine the accurate system once tenders are received.

1.3 Points for this tender (even in the case of a tender for income-generating contracts) shall be awarded for:

- (a) Price; and
- (b) Specific Goals.

1.4 **To be completed by the organ of state:**

The maximum points for this tender are allocated as follows:

	POINTS	POINTS
PRICE	80	90
SPECIFIC GOALS	20	10
<b>Total points for Price and SPECIFIC GOALS</b>	<b>100</b>	<b>100</b>

1.5 Failure on the part of a tenderer to submit proof or documentation required in terms of this tender to claim points for specific goals with the tender, will be interpreted to mean that preference points for specific goals are not claimed.

- 1.6 The organ of state reserves the right to require of a tenderer, either before a tender is adjudicated or at any time subsequently, to substantiate any claim in regard to preferences, in any manner required by the organ of state.

## 2. DEFINITIONS

- (a) “**tender**” means a written offer in the form determined by an organ of state in response to an invitation to provide goods or services through price quotations, competitive tendering process or any other method envisaged in legislation;
- (b) “**price**” means an amount of money tendered for goods or services, and includes all applicable taxes less all unconditional discounts;
- (c) “**rand value**” means the total estimated value of a contract in Rand, calculated at the time of bid invitation, and includes all applicable taxes;
- (d) “**tender for income-generating contracts**” means a written offer in the form determined by an organ of state in response to an invitation for the origination of income-generating contracts through any method envisaged in legislation that will result in a legal agreement between the organ of state and a third party that produces revenue for the organ of state, and includes, but is not limited to, leasing and disposal of assets and concession contracts, excluding direct sales and disposal of assets through public auctions; and
- (e) “**the Act**” means the Preferential Procurement Policy Framework Act, 2000 (Act No. 5 of 2000).

## 3. FORMULAE FOR PROCUREMENT OF GOODS AND SERVICES

### 3.1. POINTS AWARDED FOR PRICE

#### 3.1.1 THE 80/20 PREFERENCE POINT SYSTEMS

A maximum of 80 or 90 points is allocated for price on the following basis:

**80/20**

$$Ps = 80 \left( 1 - \frac{Pt - Pmin}{Pmin} \right)$$

Where

Ps = Points scored for price of tender under consideration

Pt = Price of tender under consideration

Pmin = Price of lowest acceptable tender

### 3.2. FORMULAE FOR DISPOSAL OR LEASING OF STATE ASSETS AND INCOME GENERATING PROCUREMENT

### 3.2.1. POINTS AWARDED FOR PRICE

A maximum of 80 or 90 points is allocated for price on the following basis:

**80/20**

$$P_s = 80 \left( 1 + \frac{P_t - P_{max}}{P_{max}} \right)$$

Where

- $P_s$  = Points scored for price of tender under consideration  
 $P_t$  = Price of tender under consideration  
 $P_{max}$  = Price of highest acceptable tender

## 4. POINTS AWARDED FOR SPECIFIC GOALS

- 4.1. In terms of Regulation 4(2); 5(2); 6(2) and 7(2) of the Preferential Procurement Regulations, preference points must be awarded for specific goals stated in the tender. For the purposes of this tender the tenderer will be allocated points based on the goals stated in table 1 below as may be supported by proof/ documentation stated in the conditions of this tender:
- 4.2. In cases where organs of state intend to use Regulation 3(2) of the Regulations, which states that, if it is unclear whether the 80/20 or 90/10 preference point system applies, an organ of state must, in the tender documents, stipulate in the case of—
- (a) an invitation for tender for income-generating contracts, that either the 80/20 or 90/10 preference point system will apply and that the highest acceptable tender will be used to determine the applicable preference point system; or
  - (b) any other invitation for tender, that either the 80/20 or 90/10 preference point system will apply and that the lowest acceptable tender will be used to determine the applicable preference point system,
- then the organ of state must indicate the points allocated for specific goals for both the 90/10 and 80/20 preference point system.

**Table 1: Specific goals for the tender and points claimed are indicated per the table below.**

***(Note to organs of state: Where either the 90/10 or 80/20 preference point system is applicable, corresponding points must also be indicated as such.)***

**Note to tenderers: The tenderer must indicate how they claim points for each preference point system.)**

The specific goals allocated points in terms of this tender	Number of points allocated (90/10 system) (To be completed by the organ of state)	Number of points allocated (80/20 system) (To be completed by the organ of state)	Number of points claimed (90/10 system) (To be completed by the tenderer)	Number of points claimed (80/20 system) (To be completed by the tenderer)
51 % + owned by HDIs (people who had no franchise on national elections prior to 1994)	3	6		
51 % + owned by Women	2	4		
51 % + owned by Youth	2	4		
51 % + owned by People with disabilities	1	2		
BEE status Level:1- 4	1	2		
Implementation of RDP goals (Any goal/s	1	2		

#### DECLARATION WITH REGARD TO COMPANY/FIRM

4.3. Name of company/firm.....

4.4. Company registration number: .....

4.5. TYPE OF COMPANY/ FIRM

- Partnership/Joint Venture / Consortium
- One-person business/sole propriety
- Close corporation
- Public Company
- Personal Liability Company
- (Pty) Limited
- Non-Profit Company
- State Owned Company

[TICK APPLICABLE BOX]

4.6. I, the undersigned, who is duly authorised to do so on behalf of the company/firm, certify that the points claimed, based on the specific goals as advised in the tender, qualifies the company/ firm for the preference(s) shown and I acknowledge that:

- i) The information furnished is true and correct;
- ii) The preference points claimed are in accordance with the General Conditions as indicated in paragraph 1 of this form;
- iii) In the event of a contract being awarded as a result of points claimed as shown in paragraphs 1.4 and 4.2, the contractor may be required to furnish documentary proof to the satisfaction of the organ of state that the claims are correct;
- iv) If the specific goals have been claimed or obtained on a fraudulent basis or any of the conditions of contract have not been fulfilled, the organ of state may, in addition to any other remedy it may have –
  - (a) disqualify the person from the tendering process;
  - (b) recover costs, losses or damages it has incurred or suffered as a result of that person’s conduct;
  - (c) cancel the contract and claim any damages which it has suffered as a result of having to make less favourable arrangements due to such cancellation;
  - (d) recommend that the tenderer or contractor, its shareholders and directors, or only the shareholders and directors who acted on a fraudulent basis, be restricted from obtaining business from any organ of state for a period not exceeding 10 years, after the *audi alteram partem* (hear the other side) rule has been applied; and
  - (e) forward the matter for criminal prosecution, if deemed necessary.

.....	
<b>SIGNATURE(S) OF TENDERER(S)</b>	
<b>SURNAME AND NAME:</b>	.....
<b>DATE:</b>	.....
<b>ADDRESS:</b>	.....
	.....
	.....
	.....



## **TERMS OF REFERENCE TO REQUEST PROPOSALS FOR NEW FACILITIES AND RENOVATIONS / ENHANCEMENT OF EXISTING FACILITIES FOR ARC IRENE ANIMAL PRODUCTION AND KGORA TRAINING CENTER**

---

### **1. INTRODUCTION**

The Agricultural Research Council (ARC) is a Research Science and Technology institution of excellence in South Africa, which operates within the National System of Innovation. The ARC has a mandate for innovative and creative agricultural research, technology development and transfer aimed at the advancement of South African agriculture. The ARC Council oversees its operations, which is appointed by and accountable to the Minister for Agriculture, Forestry and Fisheries.

### **2. BACKGROUND**

Access to seed stock in the form of day-old chicks is an important barrier to entry to poultry value chains. To mitigate this risk, DALRRD initiated a poultry breeding project, starting with the establishment of a high throughput hatchery producing 50 000 chicks per week at The ARC Animal Production Poultry Breeding Unit in Gauteng Province and KGORA Training Centre in North West Mafikeng. These facilities will provide enabling infrastructure and equipment to facilitate supply of day-old chicks to smallholder poultry farmers as part of the economic development to revitalise rural economies.

### **3. OBJECTIVE**

The agricultural research council seeks to appoint a service provider/s who will be responsible for refurbishment of the current and build new facilities to ensure the timely and successful completion of projects in the establishment of high throughput poultry operation for Gauteng ARC: Irene animal production Institute and KGORA training Centre in North West Mafikeng

### **4. TERMS OF REFERENCE AND SCOPE OF WORK**

**NB: ANNEXURE A (ARC: IRENE ANIMAL PRODUCTION TERMS AND SCOPE OF WORKS)**

**ANNEXURE B (KGORA TRAINING CENTRE TERMS SCOPE OF WORKS)**

### **5. EXPECTED DELIVERABLES /OUTCOME**

- Assessment report of the land where structures will be built (e.g. Sinkholes are prevalent in the area) for ARC Irene
- Environmental impact study where new structures will be built at Kgora training centre.
- Fully approved municipal plans for both KGORA and ARC Irene
- Architectural drawings of the proposed new and existing structures at both KGORA and ARC Irene
- A comprehensive BOQ for both KGORA and ARC Irene
- Gant chart
- Activities and milestones
- Critical path activities
- Timeline for delivery
- Fully Refurbished/Renovated and Newly built facilities

### **6. DURATION OF THE PROJECT**

The duration of the project is eight (8) months for both KGORA and ARC Irene respectively after signing of an SLA and a valid Purchase order.



**Venue:** ARC Irene campus, Old, Olifantsfontein Rd, Irene, 0062 (Main Building)

**Date:** 11 March 2025

**Time:** 10H00 AM

**Venue:** KGORA training centre North West Mafikeng

**Date:** 13 March 2025

**Time:** 10H00 AM

## 7. EVALUATION CRITERIA

The evaluation for this bid will be carried out in the following Five (5) phases

1. PRE-COMPLIANCE
2. MANDATORY
3. FUNCTIONALITY CRITERIA
4. SITE INSPECTION
5. PRICE AND SPECIFIC GOALS

### 1. PRE-COMPLIANCE

During this phase bid documents will be screened for compliance with administrative requirements as indicated below

ITEM NO.	ADMINISTRATIVE REQUIREMENTS	CHECK/COMPLIANCE
1	Master Bid Document	Provided and bound
2	SCM - SBD 1 - Invitation to Bid	Completed and signed
3	SCM- SBD 3.3 –	N:B CLEARLY MARKED FINANCIAL PROPOSALS FOR ARC IRENE AND KGORA TRAINING CENTRE SEPARATELY
4	SCM - SBD 4 – Bidders Disclosure	Completed and signed
5	Central Supplier database Registration	Attached CSD registration number/ Proof of CSD registration
6	Tax Compliance and CSD Registration	Attached CSD registration number/ Proof of CSD registration and/or SARS Tax Pin
7	SCM - SBD 6.1 - Preference Points Claim Form in terms of the Preferential Procurement Regulations 2022	Completed and signed
8	In case of bids where Consortia / Joint Ventures, Consortia/Joint Venture agreement signed by both parties must be submitted with bid proposal	JV agreement completed and signed, if applicable

## 2. MANDATORY REQUIREMENTS

NO	MANDATORY REQUIREMENT	ATTACHED PROOF YES/NO
1	IT IS ESTIMATED THAT TENDERERS MUST HAVE A CIDB CONTRACTOR GRADING DESIGNATION OF 7 GB OR HIGHER (CIDB CERTIFICATES OR CRS NUMBERS MUST BE PROVIDED) ALL PARTNERS TO A JV MUST BE INDIVIDUALLY REGISTERED IN THEIR OWN RIGHT JOINT VENTURE CALCULATOR SUMS THE CAPACITY OF ALL THE JOINT VENTURE PARTNERS AND CALCULATES A GRADING DESIGNATION FOR THE JOINT VENTURE. THEIR COMBINED GRADING MAY BE DETERMINED USING THE CIDB JOINT VENTURE CALCULATOR. NB: BIDDERS ARE TO USE THE CIDB WEBSITE FOR A COMBINED GRADING FOR A JV.	
2	WIREMAN'S LICENCE	
3	COIDA REGISTRATIONS	
4	PUBLIC LIABILITY INSURANCE 10 MILLION	
5	CIVIL ENGINEER AFFILIATED WITH AN ENGINEERING BODY (ESCA)	
6	LETTER OF MANUFACTURER OF POLYETHENE PANELS AND CHROMADEK ROOFING.	
7	PROVIDE 3 SITES FOR INSPECTION OF WHICH THE ARC WILL CHOOSE ONE	

## 3. FUNCTIONALITY CRITERIA

The bidder must score a minimum of **65%**, during phase 3 (functionality/technical) of the evaluation to qualify for Phase 4 of the evaluation where only points for price and Specific goals will be considered

The following values/ indicators will be applicable when evaluating functionality:

**BIDDERS MUST SCORE 65% TO BE EVALUATED FOR PRICE AND SPECIFIC GOALS**

**0 = Non-compliance; 1 = Poor; 2 = Fair; 3 = Average; 4 = Good; 5 = Excellent**

ITEM	FUNCTIONALITY CRITERIA	WEIGHT
1. COMPANY EXPERIENCE	<p><b>Reference letters building environmentally controlled brooder houses, open sided breeder houses and hatchery house structures</b></p> <ul style="list-style-type: none"> <li>• 3 reference letters with or above a rand value of 20million in last 15 years = 5</li> <li>• 2 reference letters with or above a rand value of 20million in last 15 years =4</li> <li>• 1 reference letters with or above a rand value of 20million in last 15 years =3</li> <li>• 0 reference letters = 0</li> </ul> <p><b>Provide copy/copies of practical completion certificates / signed reference letters on company letter head</b></p>	45

<p><b>2. Resource experience</b></p>	<p><b>Earth Moving Equipment Submit –provide proof of ownership or rental/lease agreements/letter of intent with proof of ownership from the lessor</b></p> <ul style="list-style-type: none"> <li>• 5 or more earth moving equipment e.g. TLB, Tipper trucks, grader or any other equipment relevant for the project plan <b>5 points</b></li> <li>• 4 earth moving equipment e.g. TLB, Tipper trucks, grader or any other equipment relevant for the project r the project plan <b>4 points</b></li> <li>• 3 earth moving equipment e.g. TLB, Tipper trucks, grader or any other equipment relevant for the project the project plan <b>3 points</b></li> <li>• 2 earth moving equipment e.g. TLB, Tipper trucks, grader or any other equipment relevant for the project the project plan <b>2 points</b></li> <li>• 1 earth moving equipment e.g. TLB, Tipper trucks, grader or any other equipment relevant for the project the project plan <b>1 points</b></li> </ul> <p><b>No equipment or no proof relevant for the project lease/ownership/intent letter 0 points</b></p>	<p><b>15</b></p>
<p><b>3. Technical Capability (Dedicated Team Competences</b></p>	<p><b>Project Team Qualifications &amp; Experience Submit – certified copies of qualifications, detailed CV with contactable reference and relevant experience</b></p> <ul style="list-style-type: none"> <li>➤ Project manager with experience in building poultry sites – environmentally controlled houses and hatcheries i.e. <ul style="list-style-type: none"> <li>• 10 or more years' experience -<b>5 points</b></li> <li>• 8-9 years' experience- <b>4 points</b></li> <li>• 6-7 years' experience- <b>3 points</b></li> <li>• 5 years' experience -<b>2 points</b></li> <li>• Less than 5 years' experience -<b>1 points</b></li> <li>• No experience- <b>0 points</b></li> </ul> </li> </ul> <p><b>NB:</b> Service provider must ensure to submit both documents to score points (Certified qualifications and CV with contactable references)</p>	<p><b>15</b></p>
	<p><b>Civil engineer qualification and experience</b></p> <p>5 years' experience or more as a Civil Engineer =5  4 years' experience or more as a Civil Engineer = 4  3 years' experience or more as a Civil Engineer = 3  2 years' experience or more as a Civil Engineer = 2  1 years' experience or more as a Engineer = 1</p>	<p><b>10</b></p>

**NB: BIDDERS MUST SCORE A MINIMUM OF 55% TO QUALIFY TO BE EVALUATED FOR SITE INSPECTION**

<b>4. Site Inspection evaluation</b>	<p><b>Bidders will be evaluated on site on the following criteria's as per the reference letters supplied on closing date and time of the tender.</b></p> <p><b>One (1) site</b> will be sampled and others a due diligence exercise will be conducted to ensure all facilities are existent.</p>	<b>15</b>
	<ol style="list-style-type: none"> <li>1. Proof of Three build poultry sites that includes environmentally controlled brooder houses, open sided breeder houses and the structure of hatcheries in the last 15 years = 5</li> <li>2. Proof of Two Build environmentally controlled brooder houses, open sided breeder houses and the structure of hatcheries =4</li> <li>3. Proof of 1 build environmentally controlled brooder houses, open sided breeder houses and the structure of hatcheries last 15 years = 3</li> <li>4. Proof of 0 Built environmentally controlled brooder houses, open sided breeder houses and the structure of hatcheries = 0</li> </ol>	

**NB: BIDDERS WILL COMPETE FOR PRICE AND SPECIFIC GOALS FOR ARC IRENE AND KGORA TRAINING CENTRE RESPECTIVELY**

#### **8. Price and Specific goals**

**Preference point system applicable for this bid is 80/20 or 90/10**

To advance economic transformation through the implementation of the preferential point system as stipulated in the Procurement Regulations 2022.

#### **10.1 Specific Goals**

**A full CSD Report, BBB-EE Certificate and will be required for verification of the claim for points.**

#### **SPECIFIC GOALS**

**The preference point system that will be applicable to this bid is 80/20 OR 90/10 preference points system**

	<b>SPECIFIC GOALS</b>	<b>POINTS</b>	<b>POINTS</b>
1	<b>51 % + owned by HDIs (people who had no franchise on national elections prior to 1994)</b>	<b>6</b>	<b>3</b>
2	<b>51 % + owned by Women</b>	<b>4</b>	<b>2</b>
3	<b>51 % + owned by Youth</b>	<b>4</b>	<b>2</b>
4	<b>51 % + owned by People with disabilities</b>	<b>2</b>	<b>1</b>
5	<b>BEE status Level:1- 4</b>	<b>2</b>	<b>1</b>
	<b>Implementation of RDP goals (Any goal/s</b>	<b>2</b>	<b>1</b>
	<b>TOTAL FOR SPECIFIC GOALS</b>	<b>20</b>	<b>10</b>

**NB:** Implementing the programmes of the Reconstruction and Development Programme as published in Government Gazette No. 16085 dated 23 November 1994.

As listed below:

- The promotion of South African owned enterprises.
- The promotion of export orientated production to create jobs.
- The promotion of SMMEs.
- The creation of new jobs or the intensification of labour absorption.
- The promotion of enterprises located in a specific province for work to be done or services to be rendered in that province.
- The promotion of enterprises located in a specific region for work to be done or services to be rendered in that region.
- The promotion of enterprises located in a specific municipal area for work to be done or services to be rendered in that municipal area.
- The promotion of enterprises located in rural areas.
- The empowerment of the work force by standardising the level of skill and knowledge of workers.
- The development of human resources, including by assisting in tertiary and other advanced training programmes, in line with key indicators such as percentage of wage bill spent on education and training and improvement of management skills; and
- The upliftment of communities through, but not limited to, housing, Transport, schools, infrastructure donations, and charity organisations.

## **PRICE**

The Bid will be awarded to a bidder with the highest points on price and Specific goals on condition that they have met all phases of the evaluation criteria and complied with the tender requirements set out in the tender document. The bidder will be allocated 80 of the price and 20 for SPECIFIC GOALS

The points scored by a tenderer in respect of SPECIFIC GOALS contemplated in section 5, read with section 2(1)(b)(i) and (ii) and 2(1)(c), of the Preferential Procurement Policy Framework Act, 2000 (Act No. 5 of 2000), and with effect from 16 January 2023. Made the regulations set out in the Preferential Procurement Regulations 2022 Schedule

section 2(1)(e) of the Act an organ of state must, in the invitation to submit tenders, clearly specify the specific goals for which a point may be awarded, must be added to the points scored for price

## **11. BID SUBMISSION REQUIREMENTS**

Bidders should ensure that the following submission requirements, which will be needed for are included in their bid proposal and are as follows:

1. The service provider must draft a table of contents which will indicate where each document is located in the proposal.
2. The proposal shall consist of one master original document, and must clearly indicate the Prices on SBD 3.3

3. A joint venture or consortium must submit a consolidated B-BBEE certificate based on the weighted members participation in order to earn B-BBEE points issued by SANAS accredited agency
4. The information in the CV of the proposed Team/ Project Leader should include relevant Experience in the chosen area of expertise
5. Project reference specifying the role played by the service provider in the listed projects or Assignments, project value and the duration of the project (start and end date).
6. A detailed Project Plan with clear indication of who will be responsible for the management of the assignment as well as its execution. The allocation of team members on the assignments should be based on the experience in delivering the scope of work as listed.
7. Standard bidding documents (SBD1, 3.3, 4, 6.1).
8. Copy of Central Supplier Database (CSD) report/ SARS Tax Status Pin.

## **12. LEGISLATIVE FRAMEWORK OF THE BID**

### **Tax Legislation**

1. Bidder must at all times attempt to be compliant when submitting proposal to ARC and remain Compliant for the entire contract term with all applicable tax legislation, including but not limited to the Income Tax Act, 1962 (Act No. 58 of 1962) and Value Added Tax Act, 1991 (Act No. 89 of 1991).
2. Bidders who make taxable supplies in excess of R1 million in any 12-month consecutive period are liable for compulsory VAT registration, but a person may also choose to register voluntarily provided that the minimum threshold of R500 000 has been exceeded in the past 12-month period.
3. Bidders who meet the above requirement must register as VAT vendors, if successful, within one month of award of the bid.
5. SARS Tax Status Pin requirements/ or Central Supplier Database (CSD) number or report must be provided.

### **13. PROCUREMENT LEGISLATION**

1. Bidders should be cognisant of the legislation and/or standards specifically applicable to the services.
2. If the application is made by a joint Venture or Partnership, the accreditation credentials in the name of the joined entities should be submitted. Members in the joint venture must meet the requirement of the proposal.

### **14. PRIVACY AND PROTECTION OF PERSONAL INFORMATION ACT 4 OF 2013**

protecting personal information is important to the Agricultural Research Council , and the environment. To do so, ARC follows general principles in accordance with applicable privacy Laws and the Protection of Personal Information Act 4 of 2013 (POPIA).

1. ARC'S role as the responsible party is, amongst others to process personal information for the intended purpose for which it was obtained and in line with legal agreements with its respective/ prospective services providers and third parties

2. ARC will process personal information only with the knowledge and authorisation of the Bidder/respondent and will treat personal information which comes to its knowledge as Confidential and will not disclose it, unless so required by law or subject to the exception Contained in the POPIA.

3. ARC reserves all the rights afforded to it by the POPIA in the processing of any of its Information as contained in this bid and the bidder/respondent is required to comply with all Prescripts as detailed in the POPIA relating to all information concerning ARC.

4. In responding to this bid, , ARC acknowledges that it will obtain and have access to personal information of the bidder/respondent. ARC agrees that it shall only process the information disclosed by the bidder/respondent in their response to this bid for the purpose of evaluation and subsequent award of the tender and in accordance with any applicable law

#### **15. SPECIAL CONDITIONS OF CONTRACT.**

1. The bidder will be required to provide a methodology and project plan with milestones to track progress of the Eight (08) Months duration.
2. The contractor shall provide a progress report on a monthly basis and where progress is not satisfactory Procurement Policy and Guidelines will guide the outcomes.
3. All the conditions specified in the General Conditions of Contract (GCC) will apply and where the Conditions in the special conditions of contract contradicts the conditions in the general conditions of contract the special conditions of contract will prevail
4. Letter of Authority to sign documents on behalf of the company.
5. The proposals should be submitted with all required information containing technical information.
6. Bidders failing to meet mandatory requirements, and functionality Minimum score will automatically be disqualified.
7. Service providers are requested to submit a Central supplier registration report to claim for specific goals, as well as BEEE certificate/ sworn affidavit.
8. SBD 6.1 must also be duly completed, signed, and submitted alongside the bid to claim preference points. Failure to do so will result in specific goals being forfeited.
9. If the application is made by a Joint Venture or Partnership, the accreditation credentials in name of joined entities should be submitted. Members in the joint venture must meet the requirement of the proposal and provide Authority to sign letter of behalf of the JV
10. Poor or non-performance by the bidder will result in cancellation of works orders.



## **16. SUB-CONTRACTING CONDITIONS/ REQUIREMENTS**

1. In a case a tenderer is intending to sub-contract portion of work, such tenderer awarded a contract may only enter into sub-contracting arrangements with the approval of the department In relation to a designated sector, a contractor will not be allowed to subcontract in such a manner that the local production and content of the overall value of the contract is reduced to below the stipulated minimum threshold.

2. The contractor is not allowed to sub-contract more than 25% of the contract value after award to another enterprise that does not have equal or higher B-BBEE status level, unless the intended sub-contractor is an EME that has the capability and ability to execute the sub-contract.

## **17. PAYMENT TERMS**

1. ARC undertakes to pay out in full or as per deliverables within thirty (30) days all valid claims for work done to its satisfaction upon presentation of a substantiated claim and the required reports stipulated in special conditions. No payment will be made where there is outstanding information/ work not submitted by the Service Provider/s until that outstanding information is submitted.

## **18. TECHNICAL ENQUIRIES**

**Name:** Dr. Tinette Van Wyk

**Contact number:** 012 672-9035

**Email:** [VanWykT@arc.agric.za](mailto:VanWykT@arc.agric.za)

## **19. SCM ENQUIRIES**

**Name:** Mr Sizo Ngomane

**Contact number:** 012 672 9120

**Email:** [ngomanesj@arc.agric.za](mailto:ngomanesj@arc.agric.za)



**ARC IRENE BUILD NEW BROODER HOUSES, REFERBISHMENT OF BREEDER HOUSES, OFFICE BLOCK, HATCHERY REFURBISHMENT**

Province	Site	Required infrastructure and equipment	Specification
Gauteng	Irene, ARC Animal Production campus	<b>RENOVATIONS AND / ENHANCEMENT OF EXISTING BREEDER HOUSES, OFFICE BLOCK, HATCHERY, AND BUILDING NEW BROODER HOUSES AND STOREROOMS</b>	<p><b><u>Building 2 new brooding houses</u></b></p> <ul style="list-style-type: none"> <li>• 2 x new fully environmentally controlled rearing houses, 30m x 13m with pitched roof.</li> <li>• 100mm concrete floor with fibres, Insulated panels: 75mm side panels, 100mm gable end panels, hot dip galvanised portal frame structure, 65mm polystyrene ceiling with chromadek skin one side, white chromadek roof sheets.</li> <li>• Concrete apron 3,5m x 3m in front of loading doors.</li> <li>• Small 2m x 3m control room in house for boot change etc. 1 x loading door and 2 x personnel doors (House to be completely sealed with no air leakage)</li> <li>• SKOV Ventilation system: Fully controlled environment-Fans and inlets to have full dark out (light filters), 24v emergency opening on battery back- up that needs a standby generator.</li> <li>• Fully dimmable LED lighting system</li> <li>• Heating system: Gas heaters 55kw each or Bosman stove heating (with backup heater)</li> <li>• Gas installation with authorised gas installer</li> <li>• Control system with mini ups and alarms</li> </ul>

			<ul style="list-style-type: none"> <li>• 10 x pens 3,5m x 3,5m to house 3,430 birds (28birds/ SqM)- Aluminium pens designed to be removed and reinstalled after each cycle.</li> <li>• 3 x scratch tray per pen</li> <li>• 2 x Tube feeders per pe</li> <li>• 2 x Bell drinkers per pen</li> </ul> <p><b>Refurbishment of Laying house 1-7 (47m X 11m x 2.2H) and converting one rearing house (6-12w) into a layer house</b></p> <ul style="list-style-type: none"> <li>• 420 bell drinkers and 420 tube feeders</li> <li>• Replace existing pens with new pens. 30 Pens per house (3 x 4.9m) Aluminium pens designed to be removed and reinstalled after each cycle.</li> <li>• 2x Tube feeders per pen, 2 x Bell drinkers per pen</li> <li>• Paint all the 7 breeder houses inside and out</li> <li>• Paint roofs WHITE</li> <li>• Replace al doors with new doors</li> <li>• Concrete apron 3,5m x 3m in front of loading doors that is inside a double door entry with a roof, steel frame, diamond mesh, steel bench, with a concrete footbath on both sides of the bench that can drain out</li> <li>• Concrete apron around house</li> <li>• Replace or fix the electrical works inside each house up to COC standards</li> <li>• Installation of stirring fans x 2 per house</li> <li>• Replace damaged side curtains (800mm X 47m) for each house.</li> <li>• Install 8 X 100 liters JoJo tanks on each of the house.</li> <li>• Supply and install hand washing stations at each house.</li> </ul>
--	--	--	---

			<ul style="list-style-type: none"> <li>• 2 x Silos 18t each that would supply whole farm of feed, next to the fence. For Laying feed</li> <li>• Refurbish current nest boxes on adjustable steel frames. 2 x nest boxes (6-hole nest box) per pen</li> <li>• Bogey egg trolleys (Egg collection trolley hanging from the roof that are moveable)</li> </ul> <p><b>Refurbishment of office block</b> 24m X 5m divided in a hatchery side and farms side with no contact in-between them</p> <ul style="list-style-type: none"> <li>• <b>Hatchery side</b> must include an office, showers with dirty and clean side, lockers on dirty side of showers, shelves for storage for clean PPE on clean side of shower, canteen on clean side, Industrial size washing machine and tumble dryer on clean side.</li> <li>• <b>Farm side</b> must include shower with dirty and clean side, lockers on dirty side of showers, shelves for storage for clean PPE on clean side of shower, canteen on clean side, Industrial size washing machine and tumble dryer on clean side.</li> <li>• Roof, and the ceiling, tiles, aircon, painting of building and roof.</li> <li>• New office furniture</li> <li>• Aircon in office</li> </ul> <p><b>Egg collection room in fence between farm and hatchery</b></p> <ul style="list-style-type: none"> <li>• Air conditioner</li> <li>• Roller doors on both sides</li> <li>• Fumigation equipment</li> </ul>
--	--	--	--

			<p><b>Hatchery</b>  Building a new hatchery on existing foundation with the capacity to produce 50 000 chicks per week.</p> <ul style="list-style-type: none"> <li>• Building size must be: 52m x 14m (Extension of the current hatchery foundation is needed)</li> </ul> <p><b>The building must include</b></p> <ul style="list-style-type: none"> <li>• Egg receiving room</li> <li>• Egg holding room</li> <li>• Setter room</li> <li>• Transfer room</li> <li>• Hatcher room</li> <li>• Takeoff room</li> <li>• Chick handling and vaccination room</li> <li>• Storeroom</li> <li>• All electrical including generator incoming connection and plumbing works</li> <li>• Extension of concrete slab Infront of hatchery to the fence and dispatch area.</li> <li>• Build a dispatch area under roof with a sliding gate (entry for hatchery vehicles as well)</li> <li>• New parking area outside dispatch side of hatchery</li> </ul> <p><b>Building a new storeroom (Size 12 x 24m)</b></p> <ul style="list-style-type: none"> <li>• For brooding feed storage, housekeeping equipment, packaging material, shavings, pallets</li> <li>• New plastic pallets to store feed bags on.</li> <li>• Electrical supply and lighting</li> <li>• Supply of a Chest freezer 580L for mortalities</li> </ul> <p><b>Building a new 100 000l reservoir</b></p> <ul style="list-style-type: none"> <li>• Corrugated steel dam isolated with roof</li> <li>• 2.5 Kv pressure Pump</li> </ul>
--	--	--	---

			<ul style="list-style-type: none"><li>• Must supply Hatchery, breeder houses and rearing houses</li><li>• Food Grade Multi-layered Liner</li><li>• 1 x 50mm Outlet &amp; Ball Valve</li><li>• 1 x Tank Inlet (Leaf Filter Basket or 50mm Inlet)</li><li>• 1 x 100mm Bell Mouth Overflow</li><li>• 1 x Lockable Access Hatch</li><li>• 1 x Removable Ladder</li><li>• Magnesium Sacrificial Anodes for corrosion protection</li></ul>
--	--	--	--

Province	Site	Required infrastructure and equipment	TERMS OF REFERENCE AND SCOPE OF WORKS
<b>New hatchery site – 50 000 chicks /week</b>			
Mafikeng	KGORA training center	<b>Hatchery, 4 x Breeder houses and 2 x rearing houses</b>	<p><b><u>Build and install 2 new brooding houses</u></b></p> <ul style="list-style-type: none"> <li>• 2 x new fully environmentally controlled rearing houses, 30m x 13m with pitched roof.</li> <li>• 100mm concrete floor with fibres, Insulated panels: 75mm side panels, 100mm gable end panels, hot dip galvanised portal frame structure, 65mm polystyrene ceiling with chromadek skin one side, white chromadek roof sheets.</li> <li>• Concrete apron 3,5m x 3m in front of loading doors.</li> <li>• Small 2m x 3m control room in house for boot change etc. 1 x loading door and 2 x personnel doors (House to be completely sealed with no air leakage)</li> <li>• SKOV Ventilation system: Fully controlled environment-Fans and inlets to have full dark out (light filters), 24v emergency opening on battery back- up that needs a standby generator.</li> <li>• Fully dimmable LED lighting system</li> <li>• Heating system: Gas heaters 55kw each or Bosman stove heating (with backup heater)</li> <li>• Gas installation with authorised gas installer</li> <li>• Control system with mini ups and alarms</li> <li>• 200 x scratch trays</li> </ul>

			<ul style="list-style-type: none"> <li>• 100 x Tube feeders per house</li> <li>• 3 x rows of nipple drinkers per house</li> <li>• All electrical automated lights</li> <li>• Electrical works inside each house up to COC standards</li> <li>• Install 100 liters JoJo tank per house</li> <li>• Supply and install hand washing stations at each house.</li> <li>• 12t Feed Silo at each house</li> </ul> <p><b>Build and install 4 new broiler breeder houses (50m X 15m)</b></p> <ul style="list-style-type: none"> <li>• 4 x new fully environmentally controlled breeder houses 50m x 15m with pitched roof.</li> <li>• 100mm concrete floor with fibres, Insulated panels: 75mm side panels, 100mm gable end panels, hot dip galvanised portal frame structure, 65mm polystyrene ceiling with chromadek skin one side, white chromadek roof sheets.</li> <li>• Concrete apron 3,5m x 3m in front of loading doors that is inside a double door entry with a roof, steel frame, diamond mesh, steel bench, with a concrete footbath on both sides of the bench that can drain out</li> <li>• Concrete apron around house</li> <li>• Small 2m x 3m control room in front of house for boot change etc. 1 x loading door and 2 x personnel doors (House to be completely sealed with no air leakage)</li> <li>• SKOV Ventilation system: Fully controlled environment-Fans and inlets to have full dark out (light filters), 24v emergency opening on battery back- up that needs a standby generator.</li> <li>• Fully dimmable LED lighting system</li> <li>• Control system with mini ups and alarms</li> <li>• Separate chain feeder lines for male and female</li> <li>• 3 x rows of nipple drinkers per house</li> <li>• All electrical automated lights</li> <li>• Electrical works inside each house up to COC standards</li> <li>• Install 4 X 100 liters JoJo tanks for each of the house</li> <li>• Supply and install hand washing stations at each house.</li> </ul>
--	--	--	--



			<ul style="list-style-type: none"> <li>• 12t Feed Silo at each house</li> <li>• Nest boxes complete with adjustable stands, top perch two bars, bottom perch four bars, removable nest pads, adjustable height, vented side panels, galv material used, 4.5 females per opening, 38 x nest boxes per</li> </ul> <p><b>Egg collection room in fence between farm and hatchery</b></p> <ul style="list-style-type: none"> <li>• Air conditioner</li> <li>• Roller doors on both sides</li> <li>• Fumigation equipment</li> </ul> <p><b>Building a new hatchery with the capacity to produce 50 000 chicks per week</b>  <b>Building size: 52m x 14m</b>  <b>The building must include</b></p> <ul style="list-style-type: none"> <li>• Egg receiving room</li> <li>• Egg holding room</li> <li>• Setter room</li> <li>• Transfer room</li> <li>• Hatcher room</li> <li>• Takeoff room</li> <li>• Chick handling and vaccination room</li> <li>• Reception, office, shower male and female, lockers on dirty side of showers, canteen, laundry rooms, storeroom</li> <li>• Dirty shower M+F, Dirty Office/Canteen, Dirty Laundry room</li> <li>• Clean shower M+F, Clean office/Canteen, Clean Laundry room</li> <li>• Industrial size washing machine and tumble dryer on hatchery side and on farm side, storage for clean PPE</li> <li>• All electrical and plumbing works</li> </ul> <p><b>Dispatch area for day old chicks</b></p> <ul style="list-style-type: none"> <li>• Steel frame structure under roof</li> <li>• Parking area</li> </ul>
--	--	--	---

			<p><b>Building a new 100 000l reservoir</b></p> <ul style="list-style-type: none"> <li>• Corrugated steel dam isolated with roof</li> <li>• 2.5 Kv pressure Pump</li> <li>• Must supply Hatchery, breeder houses and rearing house</li> <li>• Food Grade Multi-layered Liner</li> <li>• 1 x 50mm Outlet &amp; Ball Valve</li> <li>• 1 x Tank Inlet (Leaf Filter Basket or 50mm Inlet)</li> <li>• 1 x 100mm Bell Mouth Overflow</li> <li>• 1 x Lockable Access Hatch</li> <li>• 1 x Removable Ladder</li> <li>• Magnesium Sacrificial Anodes for corrosion protection</li> </ul>
<p><b>New Training hatchery to produce 3000 chicks per week</b>  <b>Building size: 20m x 12m</b></p>			
			<p><b>The building must include</b></p> <ul style="list-style-type: none"> <li>• All rooms separated by isolated walls 50mm</li> <li>• Egg receiving / Egg holding room</li> <li>• Setter room</li> <li>• Hatcher room</li> <li>• Chick handling and vaccination room</li> <li>• Reception/ office, shower male and female, lockers on dirty side of showers,</li> <li>• All electrical and plumbing works</li> </ul>
<p><b>Refurbishment of current facilities</b></p>			
			<p><b>New male and female shower facility in fence, with dirty and clean areas at layer site</b></p> <ul style="list-style-type: none"> <li>• Male and female showers with dirty and clean areas</li> <li>• Lockers on dirty side</li> <li>• Canteen on clean side</li> </ul> <p><b>Egg collection room in fence at layer site</b></p>

			<ul style="list-style-type: none"> <li>• Aircon</li> <li>• Fumigation equipment</li> <li>• New egg grading machine</li> </ul> <p><b>1 x Broiler House refurbishment.</b></p> <ul style="list-style-type: none"> <li>• Office in front of house furniture, aircon, vaccine fridge, tiled</li> <li>• House to converted to environmental controlled</li> <li>• Extension of walls with iso panels</li> <li>• Install new hanging LED lights</li> <li>• Installation of feed hopper and pan feeders</li> <li>• Additional drinker line</li> <li>• Fixing of plumbing and electrical works</li> <li>• Installation of heating systems – Bosman drier</li> <li>• Split banker for coal storage</li> <li>• Installation of new feed silo</li> <li>• Marking of the House</li> <li>• Painting the roof white</li> <li>• Repair of the ceiling</li> <li>• Repair of floor</li> <li>• New tractor and slasher to control grass</li> <li>• Concrete apron 3,5m x 3m in front of loading doors that is inside a double door entry with a roof, steel frame, diamond mesh, steel bench, with a concrete footbath on both sides of the bench that can drain out</li> <li>• Concrete apron around house</li> </ul> <p><b>3 x Rearing Houses</b></p> <ul style="list-style-type: none"> <li>• New fencing to make into one site with 3 houses</li> <li>• Concrete walkway between houses</li> <li>• Replacement of curtains, equipment and infrastructure</li> <li>• New drinkers and feeders</li> <li>• Maintenance of electricity and plumbing</li> <li>• Dividing curtain</li> </ul>
--	--	--	--

			<ul style="list-style-type: none"> <li>• Modine heaters x 3</li> <li>• Cement 500mm apron around houses</li> <li>• Repair and replacement of ceiling</li> <li>• Painting of roofs</li> <li>• 6-ton Silo with auger pipes to 3 houses</li> <li>• Concrete apron in front of loading doors that is inside a double door entry with a roof, steel frame, diamond mesh, steel bench, with a concrete footbath on both sides of the bench that can drain out</li> <li>• Concrete apron around house</li> </ul> <p><b>Layer Unit</b></p> <p>The first layer house requires full refurbishment, including the installation of new equipment and infrastructure to be the same as existing layer house</p> <p>The second layer house, which is currently used for egg production, requires the following repairs and upgrades:</p> <ul style="list-style-type: none"> <li>• Construction of new showers and laundry facilities at the main entrance with dirty shower M+F and clean shower M+F, Clean Canteen, Clean Laundry room with washing industrial washing machine and tumble drier.</li> <li>• Office area in front of poultry house with aircon, vaccine fridge</li> <li>• Converting feeding system to electronic gantry system</li> <li>• Installation of 2 stirring fans</li> <li>• Replacement and painting of ceiling</li> <li>• Replacement of curtains</li> <li>• Replacement of manure scrapers with manure belts</li> <li>• Build a manure pit at the back of the house</li> <li>• New roller doors at the back of the house</li> <li>• Painting of the roof white</li> <li>• Installation of water filters for reducing alkaline in water</li> <li>• Plastering and painting of houses</li> <li>• Concrete apron 3,5m x 3m in front of loading doors that is inside a double door entry with a roof, steel frame, diamond mesh, steel</li> </ul>
--	--	--	---

			<p>bench, with a concrete footbath on both sides of the bench that can drain out</p> <ul style="list-style-type: none"><li>• Concrete apron around house</li></ul> <p><b>Indigenous free range poultry site</b></p> <ul style="list-style-type: none"><li>• Build 4 additional houses of 4m x 7m</li><li>• 2 Bell Drinkers per house and 40 extra bell drinkers outside houses</li><li>• 2 perches per house</li><li>• New curtains for each house</li><li>• 6 Shade nets 6x 6m with steal frame</li></ul> <p><b>Build a Separate cold-room on its own site</b></p> <ul style="list-style-type: none"><li>• To accommodate all mortalities</li></ul>
--	--	--	--

# Kgora - Commercial Broiler

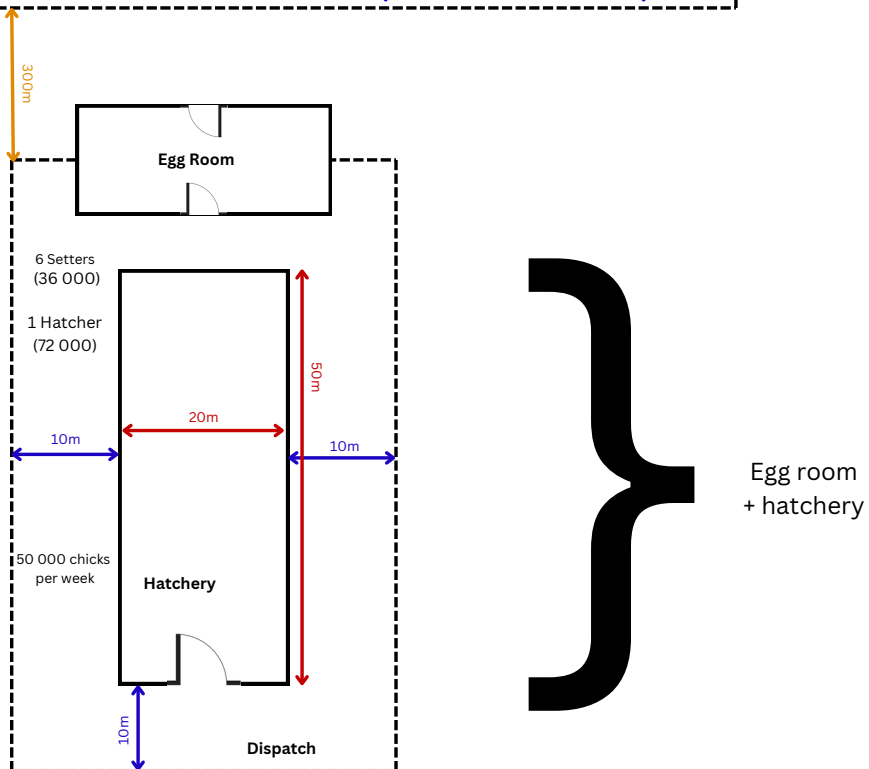
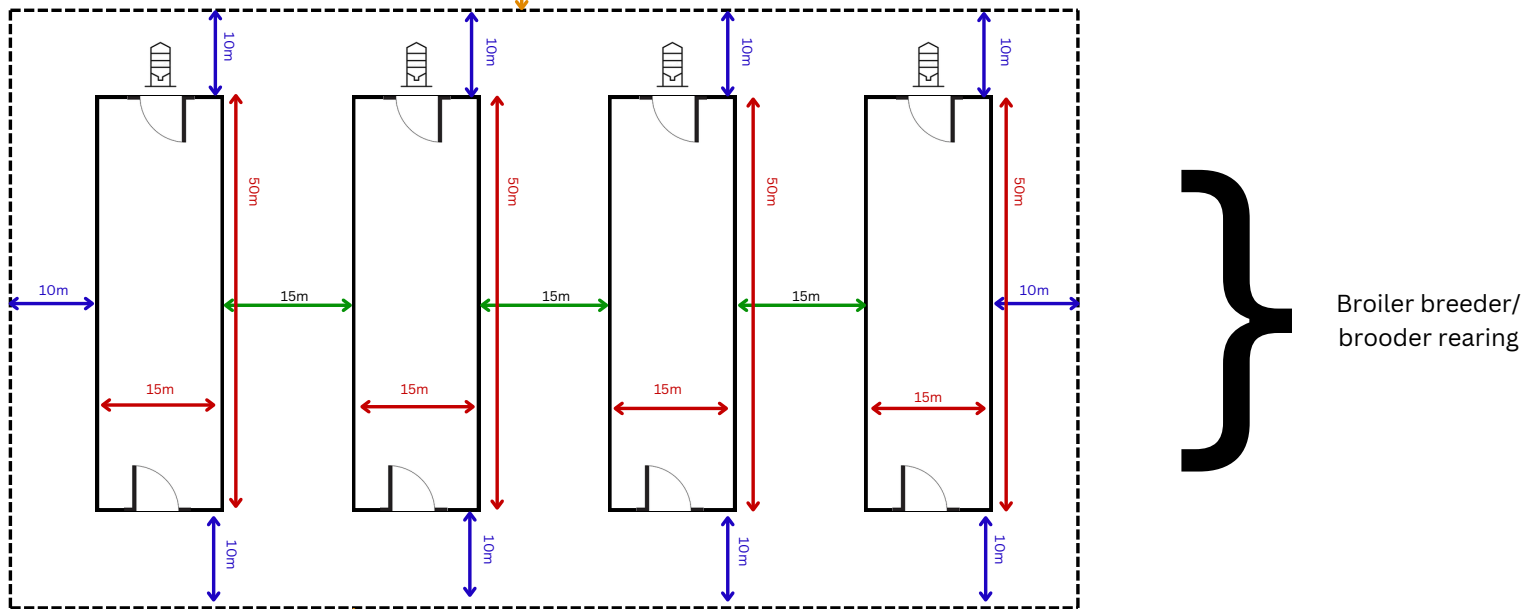
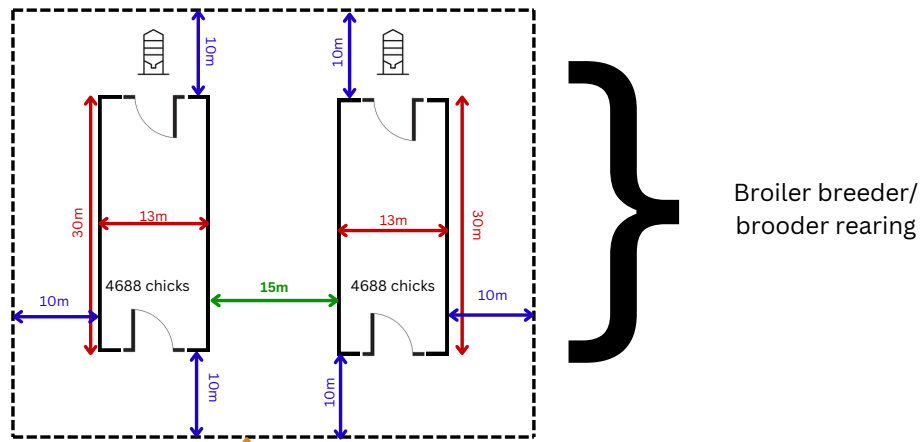

**GOVERNMENT PROCUREMENT**  
**GENERAL CONDITIONS OF CONTRACT**

**NOTES**

The purpose of this document is to:

- (i) Draw special attention to certain general conditions applicable to government bids, contracts and orders; and
- (ii) To ensure that clients be familiar with regard to the rights and obligations of all parties involved in doing business with government.

In this document words in the singular also mean in the plural and vice versa and words in the masculine also mean in the feminine and neuter.

- The General Conditions of Contract will form part of all bid documents and may not be amended.
- Special Conditions of Contract (SCC) relevant to a specific bid, should be compiled separately for every bid (if applicable) and will supplement the General Conditions of Contract. Whenever there is a conflict, the provisions in the SCC shall prevail.

## TABLE OF CLAUSES

1. Definitions
2. Application
3. General
4. Standards
5. Use of contract documents and information; inspection
6. Patent rights
7. Performance security
8. Inspections, tests and analysis
9. Packing
10. Delivery and documents
11. Insurance
12. Transportation
13. Incidental services
14. Spare parts
15. Warranty
16. Payment
17. Prices
18. Contract amendments
19. Assignment
20. Subcontracts
21. Delays in the supplier's performance
22. Penalties
23. Termination for default
24. Dumping and countervailing duties
25. Force Majeure
26. Termination for insolvency
27. Settlement of disputes
28. Limitation of liability
29. Governing language
30. Applicable law
31. Notices
32. Taxes and duties
33. National Industrial Participation Programme (NIPP)



## General Conditions of Contract

### 1. Definitions

1. The following terms shall be interpreted as indicated:
  - 1.1 “Closing time” means the date and hour specified in the bidding documents for the receipt of bids.
  - 1.2 “Contract” means the written agreement entered into between the purchaser and the supplier, as recorded in the contract form signed by the parties, including all attachments and appendices thereto and all documents incorporated by reference therein.
  - 1.3 “Contract price” means the price payable to the supplier under the contract for the full and proper performance of his contractual obligations.
  - 1.4 “Corrupt practice” means the offering, giving, receiving, or soliciting of any thing of value to influence the action of a public official in the procurement process or in contract execution.
  - 1.5 "Countervailing duties" are imposed in cases where an enterprise abroad is subsidized by its government and encouraged to market its products internationally.
  - 1.6 “Country of origin” means the place where the goods were mined, grown or produced or from which the services are supplied. Goods are produced when, through manufacturing, processing or substantial and major assembly of components, a commercially recognized new product results that is substantially different in basic characteristics or in purpose or utility from its components.
  - 1.7 “Day” means calendar day.
  - 1.8 “Delivery” means delivery in compliance of the conditions of the contract or order.
  - 1.9 “Delivery ex stock” means immediate delivery directly from stock actually on hand.
  - 1.10 “Delivery into consignees store or to his site” means delivered and unloaded in the specified store or depot or on the specified site in compliance with the conditions of the contract or order, the supplier bearing all risks and charges involved until the supplies are so delivered and a valid receipt is obtained.
  - 1.11 "Dumping" occurs when a private enterprise abroad market its goods on own initiative in the RSA at lower prices than that of the country of origin and which have the potential to harm the local industries in the RSA.
  - 1.12 ”Force majeure” means an event beyond the control of the supplier and not involving the supplier’s fault or negligence and not foreseeable.

Such events may include, but is not restricted to, acts of the purchaser in its sovereign capacity, wars or revolutions, fires, floods, epidemics, quarantine restrictions and freight embargoes.

- 1.13 “Fraudulent practice” means a misrepresentation of facts in order to influence a procurement process or the execution of a contract to the detriment of any bidder, and includes collusive practice among bidders (prior to or after bid submission) designed to establish bid prices at artificial non-competitive levels and to deprive the bidder of the benefits of free and open competition.
- 1.14 “GCC” means the General Conditions of Contract.
- 1.15 “Goods” means all of the equipment, machinery, and/or other materials that the supplier is required to supply to the purchaser under the contract.
- 1.16 “Imported content” means that portion of the bidding price represented by the cost of components, parts or materials which have been or are still to be imported (whether by the supplier or his subcontractors) and which costs are inclusive of the costs abroad, plus freight and other direct importation costs such as landing costs, dock dues, import duty, sales duty or other similar tax or duty at the South African place of entry as well as transportation and handling charges to the factory in the Republic where the supplies covered by the bid will be manufactured.
- 1.17 “Local content” means that portion of the bidding price which is not included in the imported content provided that local manufacture does take place.
- 1.18 “Manufacture” means the production of products in a factory using labour, materials, components and machinery and includes other related value-adding activities.
- 1.19 “Order” means an official written order issued for the supply of goods or works or the rendering of a service.
- 1.20 “Project site,” where applicable, means the place indicated in bidding documents.
- 1.21 “Purchaser” means the organization purchasing the goods.
- 1.22 “Republic” means the Republic of South Africa.
- 1.23 “SCC” means the Special Conditions of Contract.
- 1.24 “Services” means those functional services ancillary to the supply of the goods, such as transportation and any other incidental services, such as installation, commissioning, provision of technical assistance, training, catering, gardening, security, maintenance and other such obligations of the supplier covered under the contract.
- 1.25 “Written” or “in writing” means handwritten in ink or any form of electronic or mechanical writing.

- 2. Application**
- 2.1 These general conditions are applicable to all bids, contracts and orders including bids for functional and professional services, sales, hiring, letting and the granting or acquiring of rights, but excluding immovable property, unless otherwise indicated in the bidding documents.
- 2.2 Where applicable, special conditions of contract are also laid down to cover specific supplies, services or works.
- 2.3 Where such special conditions of contract are in conflict with these general conditions, the special conditions shall apply.
- 3. General**
- 3.1 Unless otherwise indicated in the bidding documents, the purchaser shall not be liable for any expense incurred in the preparation and submission of a bid. Where applicable a non-refundable fee for documents may be charged.
- 3.2 With certain exceptions, invitations to bid are only published in the Government Tender Bulletin. The Government Tender Bulletin may be obtained directly from the Government Printer, Private Bag X85, Pretoria 0001, or accessed electronically from [www.treasury.gov.za](http://www.treasury.gov.za)
- 4. Standards**
- 4.1 The goods supplied shall conform to the standards mentioned in the bidding documents and specifications.
- 5. Use of contract documents and information; inspection.**
- 5.1 The supplier shall not, without the purchaser's prior written consent, disclose the contract, or any provision thereof, or any specification, plan, drawing, pattern, sample, or information furnished by or on behalf of the purchaser in connection therewith, to any person other than a person employed by the supplier in the performance of the contract. Disclosure to any such employed person shall be made in confidence and shall extend only so far as may be necessary for purposes of such performance.
- 5.2 The supplier shall not, without the purchaser's prior written consent, make use of any document or information mentioned in GCC clause 5.1 except for purposes of performing the contract.
- 5.3 Any document, other than the contract itself mentioned in GCC clause 5.1 shall remain the property of the purchaser and shall be returned (all copies) to the purchaser on completion of the supplier's performance under the contract if so required by the purchaser.
- 5.4 The supplier shall permit the purchaser to inspect the supplier's records relating to the performance of the supplier and to have them audited by auditors appointed by the purchaser, if so required by the purchaser.
- 6. Patent rights**
- 6.1 The supplier shall indemnify the purchaser against all third-party claims of infringement of patent, trademark, or industrial design rights arising from use of the goods or any part thereof by the purchaser.
- 7. Performance security**
- 7.1 Within thirty (30) days of receipt of the notification of contract award, the successful bidder shall furnish to the purchaser the performance security of the amount specified in SCC.

- 7.2 The proceeds of the performance security shall be payable to the purchaser as compensation for any loss resulting from the supplier's failure to complete his obligations under the contract.
- 7.3 The performance security shall be denominated in the currency of the contract, or in a freely convertible currency acceptable to the purchaser and shall be in one of the following forms:
- (a) a bank guarantee or an irrevocable letter of credit issued by a reputable bank located in the purchaser's country or abroad, acceptable to the purchaser, in the form provided in the bidding documents or another form acceptable to the purchaser; or
  - (b) a cashier's or certified cheque
- 7.4 The performance security will be discharged by the purchaser and returned to the supplier not later than thirty (30) days following the date of completion of the supplier's performance obligations under the contract, including any warranty obligations, unless otherwise specified in SCC.

**8. Inspections,  
tests and  
analyses**

- 8.1 All pre-bidding testing will be for the account of the bidder.
- 8.2 If it is a bid condition that supplies to be produced or services to be rendered should at any stage during production or execution or on completion be subject to inspection, the premises of the bidder or contractor shall be open, at all reasonable hours, for inspection by a representative of the Department or an organization acting on behalf of the Department.
- 8.3 If there are no inspection requirements indicated in the bidding documents and no mention is made in the contract, but during the contract period it is decided that inspections shall be carried out, the purchaser shall itself make the necessary arrangements, including payment arrangements with the testing authority concerned.
- 8.4 If the inspections, tests and analyses referred to in clauses 8.2 and 8.3 show the supplies to be in accordance with the contract requirements, the cost of the inspections, tests and analyses shall be defrayed by the purchaser.
- 8.5 Where the supplies or services referred to in clauses 8.2 and 8.3 do not comply with the contract requirements, irrespective of whether such supplies or services are accepted or not, the cost in connection with these inspections, tests or analyses shall be defrayed by the supplier.
- 8.6 Supplies and services which are referred to in clauses 8.2 and 8.3 and which do not comply with the contract requirements may be rejected.
- 8.7 Any contract supplies may on or after delivery be inspected, tested or analyzed and may be rejected if found not to comply with the requirements of the contract. Such rejected supplies shall be held at the cost and risk of the supplier who shall, when called upon, remove them immediately at his own cost and forthwith substitute them with

supplies which do comply with the requirements of the contract. Failing such removal the rejected supplies shall be returned at the suppliers cost and risk. Should the supplier fail to provide the substitute supplies forthwith, the purchaser may, without giving the supplier further opportunity to substitute the rejected supplies, purchase such supplies as may be necessary at the expense of the supplier.

8.8 The provisions of clauses 8.4 to 8.7 shall not prejudice the right of the purchaser to cancel the contract on account of a breach of the conditions thereof, or to act in terms of Clause 23 of GCC.

**9. Packing**

9.1 The supplier shall provide such packing of the goods as is required to prevent their damage or deterioration during transit to their final destination, as indicated in the contract. The packing shall be sufficient to withstand, without limitation, rough handling during transit and exposure to extreme temperatures, salt and precipitation during transit, and open storage. Packing, case size and weights shall take into consideration, where appropriate, the remoteness of the goods' final destination and the absence of heavy handling facilities at all points in transit.

9.2 The packing, marking, and documentation within and outside the packages shall comply strictly with such special requirements as shall be expressly provided for in the contract, including additional requirements, if any, specified in SCC, and in any subsequent instructions ordered by the purchaser.

**10. Delivery and documents**

10.1 Delivery of the goods shall be made by the supplier in accordance with the terms specified in the contract. The details of shipping and/or other documents to be furnished by the supplier are specified in SCC.

10.2 Documents to be submitted by the supplier are specified in SCC.

**11. Insurance**

11.1 The goods supplied under the contract shall be fully insured in a freely convertible currency against loss or damage incidental to manufacture or acquisition, transportation, storage and delivery in the manner specified in the SCC.

**12. Transportation**

12.1 Should a price other than an all-inclusive delivered price be required, this shall be specified in the SCC.

**13. Incidental services**

13.1 The supplier may be required to provide any or all of the following services, including additional services, if any, specified in SCC:

- (a) performance or supervision of on-site assembly and/or commissioning of the supplied goods;
- (b) furnishing of tools required for assembly and/or maintenance of the supplied goods;
- (c) furnishing of a detailed operations and maintenance manual for each appropriate unit of the supplied goods;
- (d) performance or supervision or maintenance and/or repair of the supplied goods, for a period of time agreed by the parties, provided that this service shall not relieve the supplier of any warranty obligations under this contract; and

- (e) training of the purchaser's personnel, at the supplier's plant and/or on-site, in assembly, start-up, operation, maintenance, and/or repair of the supplied goods.

13.2 Prices charged by the supplier for incidental services, if not included in the contract price for the goods, shall be agreed upon in advance by the parties and shall not exceed the prevailing rates charged to other parties by the supplier for similar services.

#### **14. Spare parts**

14.1 As specified in SCC, the supplier may be required to provide any or all of the following materials, notifications, and information pertaining to spare parts manufactured or distributed by the supplier:

- (a) such spare parts as the purchaser may elect to purchase from the supplier, provided that this election shall not relieve the supplier of any warranty obligations under the contract; and
- (b) in the event of termination of production of the spare parts:
  - (i) Advance notification to the purchaser of the pending termination, in sufficient time to permit the purchaser to procure needed requirements; and
  - (ii) following such termination, furnishing at no cost to the purchaser, the blueprints, drawings, and specifications of the spare parts, if requested.

#### **15. Warranty**

15.1 The supplier warrants that the goods supplied under the contract are new, unused, of the most recent or current models, and that they incorporate all recent improvements in design and materials unless provided otherwise in the contract. The supplier further warrants that all goods supplied under this contract shall have no defect, arising from design, materials, or workmanship (except when the design and/or material is required by the purchaser's specifications) or from any act or omission of the supplier, that may develop under normal use of the supplied goods in the conditions prevailing in the country of final destination.

15.2 This warranty shall remain valid for twelve (12) months after the goods, or any portion thereof as the case may be, have been delivered to and accepted at the final destination indicated in the contract, or for eighteen (18) months after the date of shipment from the port or place of loading in the source country, whichever period concludes earlier, unless specified otherwise in SCC.

15.3 The purchaser shall promptly notify the supplier in writing of any claims arising under this warranty.

15.4 Upon receipt of such notice, the supplier shall, within the period specified in SCC and with all reasonable speed, repair or replace the defective goods or parts thereof, without costs to the purchaser.

15.5 If the supplier, having been notified, fails to remedy the defect(s) within the period specified in SCC, the purchaser may proceed to take such remedial action as may be necessary, at the supplier's risk and expense and without prejudice to any other rights which the purchaser may have against the supplier under the contract.

- 16. Payment**
- 16.1 The method and conditions of payment to be made to the supplier under this contract shall be specified in SCC.
- 16.2 The supplier shall furnish the purchaser with an invoice accompanied by a copy of the delivery note and upon fulfillment of other obligations stipulated in the contract.
- 16.3 Payments shall be made promptly by the purchaser, but in no case later than thirty (30) days after submission of an invoice or claim by the supplier.
- 16.4 Payment will be made in Rand unless otherwise stipulated in SCC.
- 17. Prices**
- 17.1 Prices charged by the supplier for goods delivered and services performed under the contract shall not vary from the prices quoted by the supplier in his bid, with the exception of any price adjustments authorized in SCC or in the purchaser's request for bid validity extension, as the case may be.
- 18. Contract amendments**
- 18.1 No variation in or modification of the terms of the contract shall be made except by written amendment signed by the parties concerned.
- 19. Assignment**
- 19.1 The supplier shall not assign, in whole or in part, its obligations to perform under the contract, except with the purchaser's prior written consent.
- 20. Subcontracts**
- 20.1 The supplier shall notify the purchaser in writing of all subcontracts awarded under this contracts if not already specified in the bid. Such notification, in the original bid or later, shall not relieve the supplier from any liability or obligation under the contract.
- 21. Delays in the supplier's performance**
- 21.1 Delivery of the goods and performance of services shall be made by the supplier in accordance with the time schedule prescribed by the purchaser in the contract.
- 21.2 If at any time during performance of the contract, the supplier or its subcontractor(s) should encounter conditions impeding timely delivery of the goods and performance of services, the supplier shall promptly notify the purchaser in writing of the fact of the delay, its likely duration and its cause(s). As soon as practicable after receipt of the supplier's notice, the purchaser shall evaluate the situation and may at his discretion extend the supplier's time for performance, with or without the imposition of penalties, in which case the extension shall be ratified by the parties by amendment of contract.
- 21.3 No provision in a contract shall be deemed to prohibit the obtaining of supplies or services from a national department, provincial department, or a local authority.
- 21.4 The right is reserved to procure outside of the contract small quantities or to have minor essential services executed if an emergency arises, the supplier's point of supply is not situated at or near the place where the supplies are required, or the supplier's services are not readily available.

21.5 Except as provided under GCC Clause 25, a delay by the supplier in the performance of its delivery obligations shall render the supplier liable to the imposition of penalties, pursuant to GCC Clause 22, unless an extension of time is agreed upon pursuant to GCC Clause 21.2 without the application of penalties.

21.6 Upon any delay beyond the delivery period in the case of a supplies contract, the purchaser shall, without canceling the contract, be entitled to purchase supplies of a similar quality and up to the same quantity in substitution of the goods not supplied in conformity with the contract and to return any goods delivered later at the supplier's expense and risk, or to cancel the contract and buy such goods as may be required to complete the contract and without prejudice to his other rights, be entitled to claim damages from the supplier.

## **22. Penalties**

22.1 Subject to GCC Clause 25, if the supplier fails to deliver any or all of the goods or to perform the services within the period(s) specified in the contract, the purchaser shall, without prejudice to its other remedies under the contract, deduct from the contract price, as a penalty, a sum calculated on the delivered price of the delayed goods or unperformed services using the current prime interest rate calculated for each day of the delay until actual delivery or performance. The purchaser may also consider termination of the contract pursuant to GCC Clause 23.

## **23. Termination for default**

23.1 The purchaser, without prejudice to any other remedy for breach of contract, by written notice of default sent to the supplier, may terminate this contract in whole or in part:

- (a) if the supplier fails to deliver any or all of the goods within the period(s) specified in the contract, or within any extension thereof granted by the purchaser pursuant to GCC Clause 21.2;
- (b) if the Supplier fails to perform any other obligation(s) under the contract; or
- (c) if the supplier, in the judgment of the purchaser, has engaged in corrupt or fraudulent practices in competing for or in executing the contract.

23.2 In the event the purchaser terminates the contract in whole or in part, the purchaser may procure, upon such terms and in such manner as it deems appropriate, goods, works or services similar to those undelivered, and the supplier shall be liable to the purchaser for any excess costs for such similar goods, works or services. However, the supplier shall continue performance of the contract to the extent not terminated.

23.3 Where the purchaser terminates the contract in whole or in part, the purchaser may decide to impose a restriction penalty on the supplier by prohibiting such supplier from doing business with the public sector for a period not exceeding 10 years.

23.4 If a purchaser intends imposing a restriction on a supplier or any person associated with the supplier, the supplier will be allowed a time period of not more than fourteen (14) days to provide reasons why the envisaged restriction should not be imposed. Should the supplier fail to respond within the stipulated fourteen (14) days the purchaser may regard



the intended penalty as not objected against and may impose it on the supplier.

23.5 Any restriction imposed on any person by the Accounting Officer / Authority will, at the discretion of the Accounting Officer / Authority, also be applicable to any other enterprise or any partner, manager, director or other person who wholly or partly exercises or exercised or may exercise control over the enterprise of the first-mentioned person, and with which enterprise or person the first-mentioned person, is or was in the opinion of the Accounting Officer / Authority actively associated.

23.6 If a restriction is imposed, the purchaser must, within five (5) working days of such imposition, furnish the National Treasury, with the following information:

- (i) the name and address of the supplier and / or person restricted by the purchaser;
- (ii) the date of commencement of the restriction
- (iii) the period of restriction; and
- (iv) the reasons for the restriction.

These details will be loaded in the National Treasury's central database of suppliers or persons prohibited from doing business with the public sector.

23.7 If a court of law convicts a person of an offence as contemplated in sections 12 or 13 of the Prevention and Combating of Corrupt Activities Act, No. 12 of 2004, the court may also rule that such person's name be endorsed on the Register for Tender Defaulters. When a person's name has been endorsed on the Register, the person will be prohibited from doing business with the public sector for a period not less than five years and not more than 10 years. The National Treasury is empowered to determine the period of restriction and each case will be dealt with on its own merits. According to section 32 of the Act the Register must be open to the public. The Register can be perused on the National Treasury website.

**24. Anti-dumping and countervailing duties and rights**

24.1 When, after the date of bid, provisional payments are required, or anti-dumping or countervailing duties are imposed, or the amount of a provisional payment or anti-dumping or countervailing right is increased in respect of any dumped or subsidized import, the State is not liable for any amount so required or imposed, or for the amount of any such increase. When, after the said date, such a provisional payment is no longer required or any such anti-dumping or countervailing right is abolished, or where the amount of such provisional payment or any such right is reduced, any such favourable difference shall on demand be paid forthwith by the contractor to the State or the State may deduct such amounts from moneys (if any) which may otherwise be due to the contractor in regard to supplies or services which he delivered or rendered, or is to deliver or render in terms of the contract or any other contract or any other amount which may be due to him

**25. Force Majeure**

25.1 Notwithstanding the provisions of GCC Clauses 22 and 23, the supplier shall not be liable for forfeiture of its performance security,

damages, or termination for default if and to the extent that his delay in performance or other failure to perform his obligations under the contract is the result of an event of force majeure.

25.2 If a force majeure situation arises, the supplier shall promptly notify the purchaser in writing of such condition and the cause thereof. Unless otherwise directed by the purchaser in writing, the supplier shall continue to perform its obligations under the contract as far as is reasonably practical, and shall seek all reasonable alternative means for performance not prevented by the force majeure event.

**26. Termination for insolvency**

26.1 The purchaser may at any time terminate the contract by giving written notice to the supplier if the supplier becomes bankrupt or otherwise insolvent. In this event, termination will be without compensation to the supplier, provided that such termination will not prejudice or affect any right of action or remedy which has accrued or will accrue thereafter to the purchaser.

**27. Settlement of Disputes**

27.1 If any dispute or difference of any kind whatsoever arises between the purchaser and the supplier in connection with or arising out of the contract, the parties shall make every effort to resolve amicably such dispute or difference by mutual consultation.

27.2 If, after thirty (30) days, the parties have failed to resolve their dispute or difference by such mutual consultation, then either the purchaser or the supplier may give notice to the other party of his intention to commence with mediation. No mediation in respect of this matter may be commenced unless such notice is given to the other party.

27.3 Should it not be possible to settle a dispute by means of mediation, it may be settled in a South African court of law.

27.4 Mediation proceedings shall be conducted in accordance with the rules of procedure specified in the SCC.

27.5 Notwithstanding any reference to mediation and/or court proceedings herein,

(a) the parties shall continue to perform their respective obligations under the contract unless they otherwise agree; and

(b) the purchaser shall pay the supplier any monies due the supplier.

**28. Limitation of liability**

28.1 Except in cases of criminal negligence or willful misconduct, and in the case of infringement pursuant to Clause 6;

(a) the supplier shall not be liable to the purchaser, whether in contract, tort, or otherwise, for any indirect or consequential loss or damage, loss of use, loss of production, or loss of profits or interest costs, provided that this exclusion shall not apply to any obligation of the supplier to pay penalties and/or damages to the purchaser; and

- (b) the aggregate liability of the supplier to the purchaser, whether under the contract, in tort or otherwise, shall not exceed the total contract price, provided that this limitation shall not apply to the cost of repairing or replacing defective equipment.
- 29. Governing language** 29.1 The contract shall be written in English. All correspondence and other documents pertaining to the contract that is exchanged by the parties shall also be written in English.
- 30. Applicable law** 30.1 The contract shall be interpreted in accordance with South African laws, unless otherwise specified in SCC.
- 31. Notices** 31.1 Every written acceptance of a bid shall be posted to the supplier concerned by registered or certified mail and any other notice to him shall be posted by ordinary mail to the address furnished in his bid or to the address notified later by him in writing and such posting shall be deemed to be proper service of such notice
- 31.2 The time mentioned in the contract documents for performing any act after such aforesaid notice has been given, shall be reckoned from the date of posting of such notice.
- 32. Taxes and duties** 32.1 A foreign supplier shall be entirely responsible for all taxes, stamp duties, license fees, and other such levies imposed outside the purchaser's country.
- 32.2 A local supplier shall be entirely responsible for all taxes, duties, license fees, etc., incurred until delivery of the contracted goods to the purchaser.
- 32.3 No contract shall be concluded with any bidder whose tax matters are not in order. Prior to the award of a bid the Department must be in possession of a tax clearance certificate, submitted by the bidder. This certificate must be an original issued by the South African Revenue Services.
- 33. National Industrial Participation Programme (NIP)** 33.1 The NIP Programme administered by the Department of Trade and Industry shall be applicable to all contracts that are subject to the NIP obligation.



**SUPPLIER MAINTENANCE:**

Head Office Only	
Captured By:	_____
Date Captured:	_____
Authorised By:	_____
Date Authorised:	_____
Supplier code:	_____
Enquiries. :	
Tel. No.:	_____

I/We hereby request and authorise you to pay any amounts, which may accrue to me/us to the credit of my/our account with the mentioned bank.

I/we understand that the credit transfers hereby authorised will be processed by computer through a system known as "ACB - Electronic Fund Transfer Service", and I/we understand that not additional advice of payment will be provided by my/our bank, but that the details of each payment will be printed on my/our bank statement or any accompanying voucher. (This does not apply where it is not customary for banks to furnish bank statements).

I/we understand that the Department will supply a payment advice in the normal way, and that it will indicate the date on which the funds will be made available on my/our account.

This authority may be cancelled by me/us by giving thirty days notice by prepaid registered post. Please ensure information is validate as per required bank screens .

I/We understand that bank details provided should be exactly as per the records held by the bank.

I/We understand that the Department will not assume responsibility for any delayed payments, as a result of incorrect information supplied.

**Company / Personal Details**

Registered Name	_____
Trading Name	_____
Tax Number	_____
VAT Number	_____
Title:	_____
Initials:	_____
First Name:	_____
Surname:	_____

**Postal and Street Address Detail of the Company / Individual**

Postal Address	_____					
Street Address	_____					
Postal Code	<table border="1"> <tr> <td> </td><td> </td><td> </td><td> </td><td> </td> </tr> </table>					

**New Detail**

<input type="checkbox"/>	New Supplier information	<input type="checkbox"/>	Update Supplier information																					
Supplier Type:	<input type="checkbox"/> Individual <input type="checkbox"/> Company <input type="checkbox"/> CC	<input type="checkbox"/> Department <input type="checkbox"/> Trust <input type="checkbox"/> Other ( Specify )	<input type="checkbox"/> Partnership <table border="1"> <tr> <td> </td><td> </td><td> </td><td> </td><td> </td><td> </td><td> </td><td> </td><td> </td><td> </td><td> </td><td> </td><td> </td><td> </td><td> </td><td> </td><td> </td><td> </td><td> </td><td> </td> </tr> </table>																					
Department Number	<table border="1"> <tr> <td> </td><td> </td><td> </td><td> </td> </tr> </table>																							

**Supplier Account Details**

**This field is compulsory and should be completed by a bank official from the relevant bank**

Account Name

Account Number

Branch Name

Branch Number

Account Type  Cheque Account  
 Savings Account  
 Transmission Account  
 Bond Account  
 Other (Please Specify)

ID Number

Passport Number

Company Registration Number

\*CC Registration

**\*Please include CC/CK where applicable**

Practise Number

**Bank stamp**  
 It is hereby confirmed that this details have been verified  
 against the following screens  
**ABSA-CIF** screen  
**FNB-** Hogans system on the CIS4/CUPR  
**STD** Bank-Look-up-screen  
**Nedbank-** Banking Platform under the Client Details Tab

**Contact Details**

Business

Area Code  Telephone Number  Extension

Home

Area Code  Telephone Number  Extension

Fax

Area Code  Fax Number

Cell

Cell Code  Cell Number

Email Address

Contact Person:

<input type="text"/>	<input type="text"/>
Supplier Signature	Departmental Official
<input type="text"/>	<input type="text"/>
Print Name	Print Name
<input type="text"/>	<input type="text"/>
<input type="text"/>	Rank
<input type="text"/>	<input type="text"/>
Date (dd/mm/yyyy)	Date (dd/mm/yyyy)

*Agricultural research council Office where form is submitted from*

**NB: All relevant fields must be completed**